

STANDARD MANHOLE TYPE II

PIPE CUT TO SECTION REQUIRED TO BE USED FOR CHANNEL THRU MANHOLE OR A NEATLY FORMED CHANNEL CONFORMING TO SECTION OF PIPE MAY BE USED.

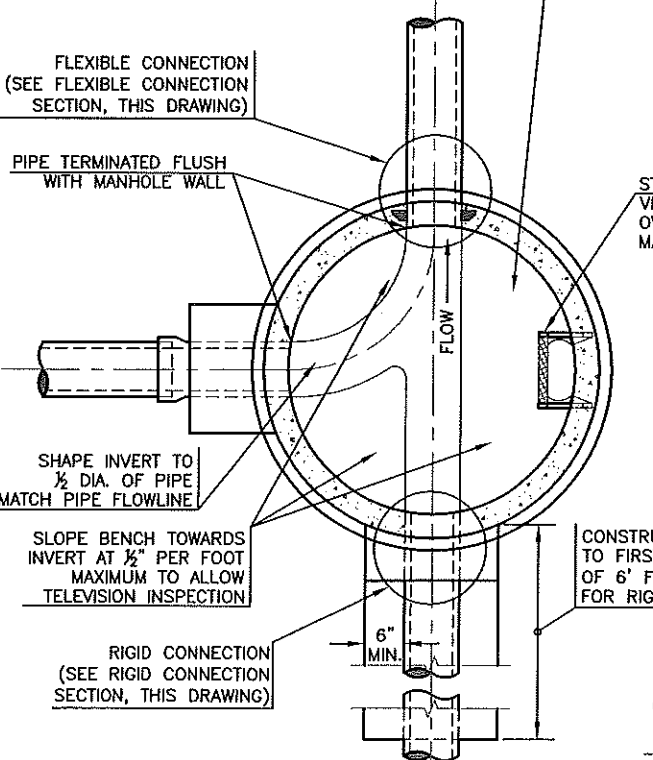

MANHOLE BOTTOM PLAN

NOTE: DEADEND MANHOLES SHALL HAVE A POURED INVERT. MUST USE BOND BREAKER BETWEEN INVERT AND FLOOR.

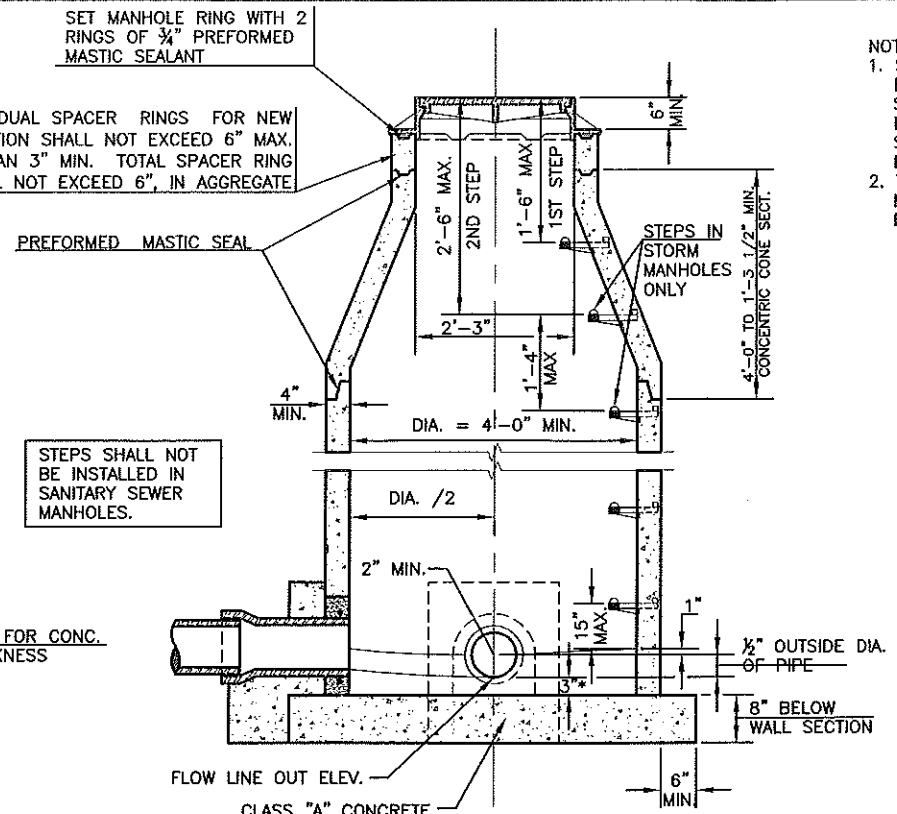

NOTE: THE BOTTOM SECTION OF ALL CAST-IN-PLACE MANHOLES AND PRECAST MANHOLES NOT BUILT MONOLITHICALLY WITH THE BASE SHALL BE SET INTO A STEEL REINFORCED (#4 @ 12" E.W.) CONCRETE BASE (4,000 PSI) A MINIMUM OF 4 INCHES. IN THIS CASE, THE BASE THICKNESS SHALL BE INCREASED TO 12 INCHES.

PRE-CAST STANDARD MANHOLE TYPE I

*THIS .3" TO BE ELIMINATED WHEN PRE-CAST INVERTS ARE USED.

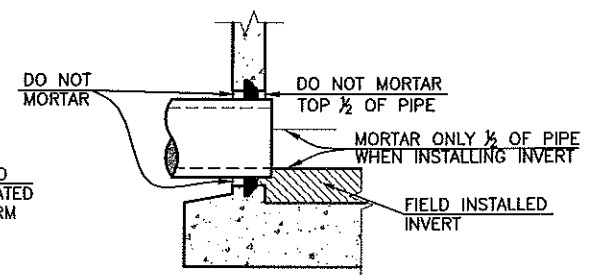

FLEXIBLE CONNECTION SECTION

FLEXIBLE CONNECTIONS SHALL BE USED FOR ALL SEWER PIPE TYPES.

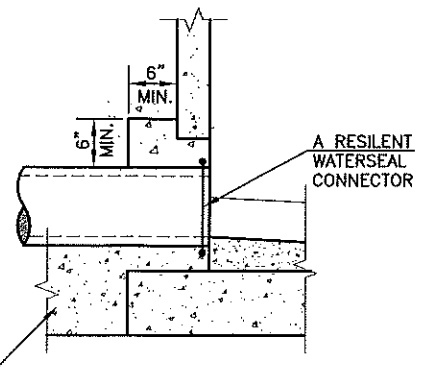

RIGID CONNECTION SECTION

RIGID CONNECTIONS SHALL BE USED FOR CERTAIN EXISTING MANHOLE CONNECTIONS AT ENGINEER'S DISCRETION.

- NOTES:
1. STAINLESS STEEL STRAPS (11 GAUGE - .1196") THICK x 1 1/2" WIDE SHALL BE COMPLETELY AROUND THE PIPE AND ATTACHED TO MANHOLE WALL WITH STAINLESS STEEL BOLTS AND ANCHORS. BOLTS SHALL BE 3/8" DIA. x 2" MIN. LENGTH AND ANCHORS SHALL BE 3/8" INSIDE DIA. x 2 1/4" LENGTH. HOLE SHALL BE DRILLED INTO MANHOLE WALL TO A DEPTH OF 2-1/2" AND LARGE ENOUGH IN DIA. TO ACCEPT ANCHORS.
 2. THIS DETAIL IS VALID ONLY FOR A SINGLE 8" INSIDE DROP IN A 5' DIA. MANHOLE, RECEIVING AN 8" DIA. SEWER. A SPECIAL DETAIL IS REQUIRED FOR ANY OTHER CONDITIONS.

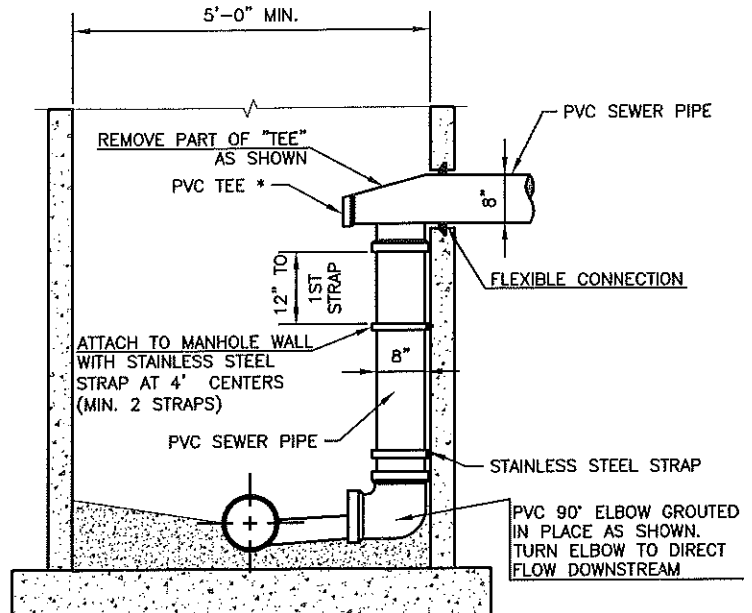

INSIDE DROP-TYPE A

NOTE: INSIDE DROP-TYPE A IS REQUIRED WHEN FLOWLINE IN AND FLOWLINE OUT ELEVATIONS DIFFER BY 1.0' OR MORE. A BOWL SYSTEM BY RELINER/DURAN INC. MAY ALSO BE USED.

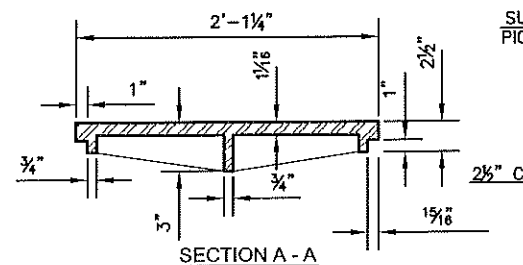

SECTION A - A

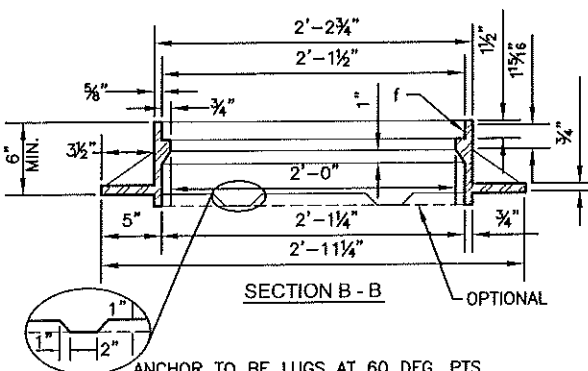

SECTION B - B

COVER

SURFACE PICKSLOT

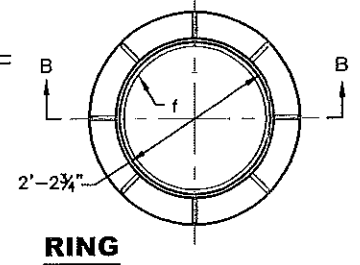

RING

MANHOLE CONSTRUCTION NOTES

- ALL MANHOLE CONSTRUCTION SHALL BE WATER TIGHT.
- TOP OF 8" FLOOR SLAB TO BE 3" MIN. BELOW FLOW LINE ELEV. OF THE OUTLET PIPE TO INSURE SUFFICIENT MIN. THICKNESS OF SHAPED INVERT.
- ALL PRECAST CONCRETE MANHOLE SECTIONS SHALL CONFORM TO A.S.T.M. DESIGNATION C478

DETAIL OF MANHOLE CASTINGS

CASTINGS SHALL CONFORM TO THE REQUIREMENTS OF "SPECIFICATIONS FOR GRAY IRON CASTINGS" IN ACCORDANCE WITH A.S.T.M. A 48, CLASS 35B.

MINIMUM TENSILE STRENGTH OF EACH CASTING SHALL BE AT LEAST 30,000 PSI.

AVERAGE WT. COVER 185 LBS., RING 220 LBS. VARIATION IN WEIGHT WILL NOT EXCEED THE SPECIFIED WEIGHTS BY MORE THAN 4%.

CASTINGS ARE TO BE MANUFACTURED TRUE TO PATTERN AND WITH SATISFACTORY FIT OF COMPONENT PARTS. CASTINGS SHALL BE FREE OF DEFECTS. DIMENSIONS AS DETAILED ON PLAN SHALL NOT DEVIATE BY MORE THAN 1/16" PER FOOT.

SEATING SURFACES OF CASTINGS SHALL BE MACHINED AS REQUIRED TO PREVENT ROCKING.

ALL CASTINGS SHALL BE FURNISHED IN BARE METAL AND SHALL HAVE MANUFACTURER'S NAME CAST INTO CASTING.

CASTINGS SHALL CONFORM TO THE PROVISIONS OF UNITED STATES CUSTOMS REGULATIONS. CASTING MANUFACTURER SHALL CARRY AT LEAST \$3,000,000 PRODUCT LIABILITY INSURANCE.

TO INSURE CONFORMANCE TO TENSILE STRENGTH REQUIREMENTS, THE FOLLOWING PROCEDURE WILL BE FOLLOWED FOR EACH LOT OF CASTINGS USED ON CITY OF TOPEKA PROJECTS.

- ALL CASTINGS SHALL BE JULIAN HEAT DATED.
- TWO TEST BAR SPECIMENS MUST BE POURED WHEN PRODUCING CITY OF TOPEKA CASTINGS. TEST BAR SPECIMENS SHALL BE DELIVERED TO PURCHASER.
- TEST REPORT FROM A CITY APPROVED INDEPENDENT LABORATORY VERIFYING TENSILE STRENGTH CHEMISTRY OR BRINELL HARDNESS SHALL ACCOMPANY EACH SHIPMENT OF CASTINGS. IF REQUESTED TEST REPORT SHALL BE PAID FOR BY THE SUPPLIER. THE HEAT DATE(S) ON CASTINGS SHALL CORRESPOND TO THE TENSILE STRENGTH REPORT(S).

"CITY OF TOPEKA SANITARY SEWER" CAST IN 2 1/2" BLOCK LETTERS AROUND CIRCUMFERENCE OF ALL COVERS INTENDED FOR WASTE WATER USE OR "CITY OF TOPEKA STORMWATER" IF INTENDED FOR STORMWATER USE

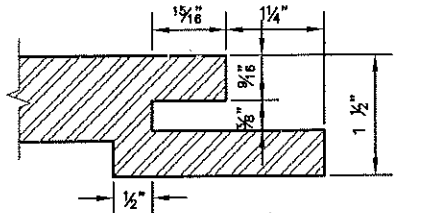

CONCEALED PICKSLOT DETAIL

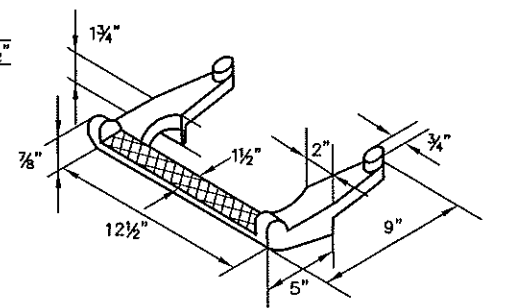

DETAIL OF CAST IRON MANHOLE STEP

(FOR PRECAST MANHOLE TO BE USED IN STORM SEWER SYSTEMS ONLY)

VESTAL MANUFACTURING NO. 918-P, CLAY AND BAILEY NO. 2115, NEEHAH NO. R-1981-I OR EQUAL AS FURNISHED BY MANUFACTURER OF PRECAST MANHOLE.

COPOLYMER POLYPROPYLENE PLASTIC STEP, PS1-PF or PS2-PF, MANUFACTURED BY M.A. IND. INC. OR APPROVED EQUAL MAY BE USED AS AN ALTERNATE TO DETAILED CASTING. THIS STEP MAY BE CAST IN PLACE OR INSTALLED IN ACCORDANCE WITH THE MANUFACTURERS RECOMMENDED INSTALLATION PROCEDURE.

NO.	DATE	REVISION	BY	APP'D
2	Dec. 2009	Mod. drop notes & added Storm. to MH	DHS	SB
1	Feb. 2008	Mod. MH Bot. Plan, Rigid Sect. & Inside Dr	DHS	SB

DRAWN BY: *m/ms*
 APP'D BY: *R. Christy*

SHAWNEE COUNTY, KANSAS
PUBLIC WORKS DEPARTMENT
 1515 NW SALINE
 TOPEKA, KS 66618
 (785) 233-7702

TOPEKA
Public Works
ENGINEERING
 620 SE MADISON ST. • 2nd Floor • TOPEKA, KS 66607
 Phone: (785) 368-3842 • Fax: (785) 368-3881

STANDARD DETAILS

STANDARD MANHOLE DETAILS
 (DT-005)

DATE: Month Year
 SHEET: X of X
 PROJ.: X-XXXXXX